

Boiler Safety Valves DN32



NEW

DUCO

Boiler Safety Valves 1¼ x 1½" KB

DUCO boiler valves to protect closed potable heated water systems against excessive pressure.

Application

The boiler valve has to be used in a closed drinking water system. Only use the valve in a dry and frostfree location.

Min/Max. system temp. 0°C / + 95°C

Safety

Check whether the max. capacity and the opening pressure that are indicated on the valve match the values of the system.

All Duco safety valves meet the requirements of the Pressure Equipment Directive (PED) "Directive 2014/68/EU Module B/Module D". The quality system also complies with the NEN-EN-ISO 9001

NORM: NEN-EN 1491

Control knob - ABS (black)

Adjustment screw - PA 6 - 15% GF

Spring seat - PBT 420 1001

Spring cover - PA 6,6 - 30%GF

Valve disk - PA 6 - 30%GF

Preset spring - Spring steel (galvanised)

Membrane - EPDM Shore Peroxide cured

Valve body - Brass (CW617N) Pb<2,2%

 This illustration is different and is only intended to explain the valve parts.

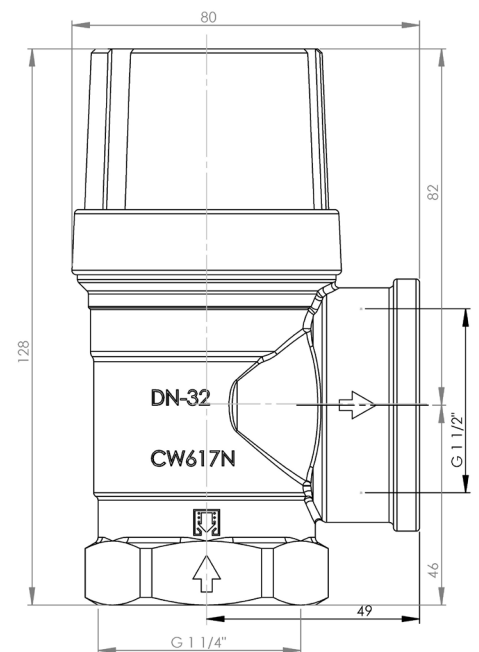
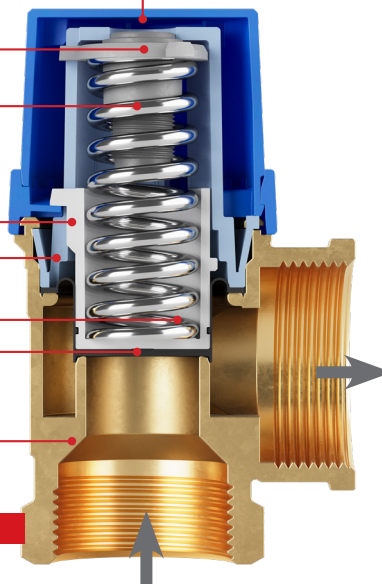

Boiler Safety Valves DN32

Article number	Set pressure bar	Heating capacity kW
1148-0-06-11	6	350
1148-0-07-11	7	350
1148-0-08-11	8	350
1148-0-09-11	9	350
1148-0-10-11	10	350

PUCO

PenTec bv
Edisonweg 7
3442 AC Woerden
The Netherlands

Tel. +31 (0)182 503 100
E-mail info@pentecbv.nl
Internet www.duco.nl
www.pentecbv.nl