

Dirt separator DDS G 1"

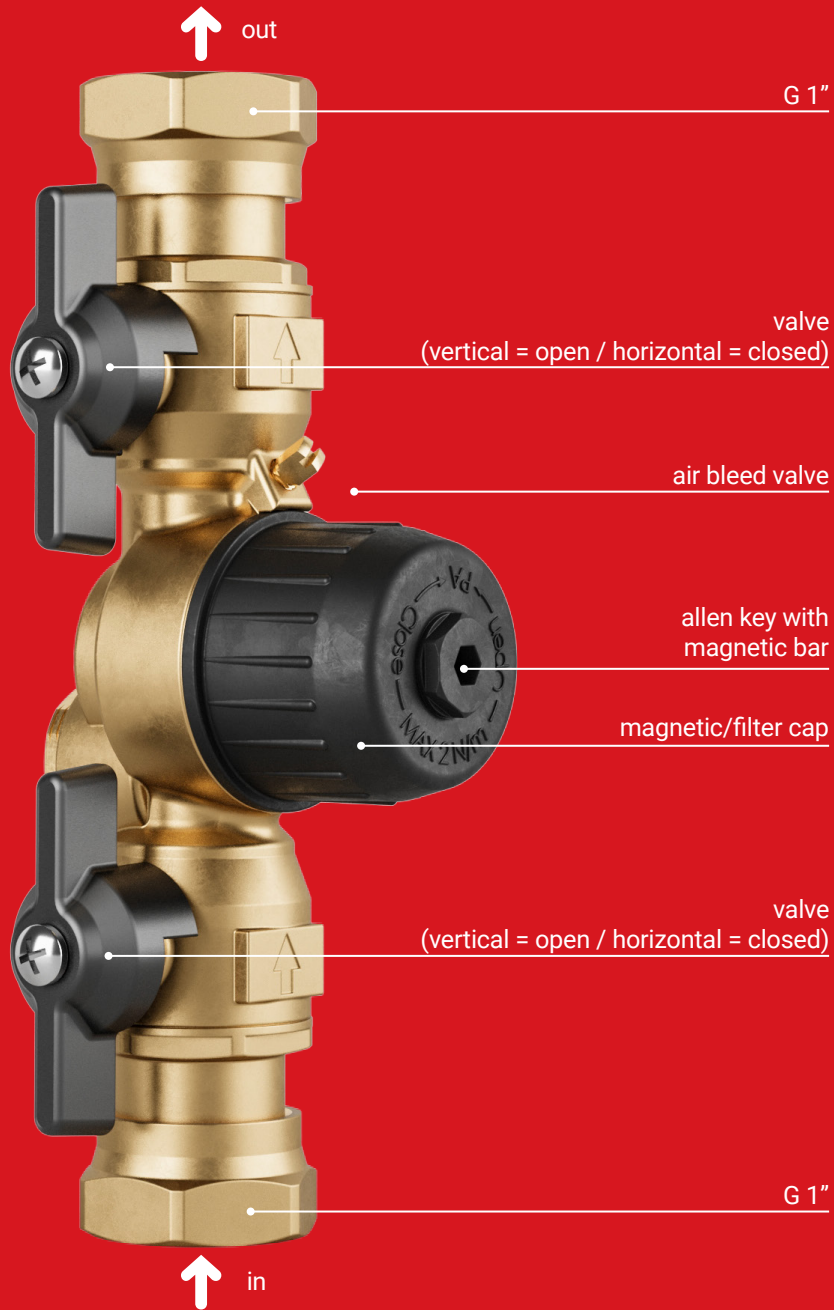

PUCO

Dirt separator DDS G 1"

The water in every central heating system eventually becomes contaminated. This occurs as a result of the oxygen in the tap water. During refilling, oxygen-rich water returns to the installation. The oxygen causes oxidation in the central heating system: iron oxides (iron particles or magnetite) are formed. These particles flow with the heating water and eventually accumulate in different places in the central heating system.

Why a dirt separator?

The new generation of energy-efficient circulation pumps in central heating boilers have a permanent magnet, making them very sensitive to 'magnetic dirt'. The dirt present in the system increases wear and tear, increases the risk of malfunctions, increases energy consumption and shortens the pump's life cycle. The dirt separator uses a fine-mesh stainless steel filter and magnet to remove the dirt from the system.

Fitting the dirt separator offers the following **ADVANTAGES**:

- **extending the life of the boiler**
- **reduces loss of return**
- **reduces maintenance**
- **reduces energy costs**
- **increases comfort**

Assembly

The dirt separator must be installed vertically in the return line in the installation.

Operation and cleaning of the stainless-steel filter

The magnets in the dirt separator collect all small iron and magnetic particles in the fine-mesh stainless steel filter. This filter must be cleaned periodically (1x per year). Cleaning the filter must be done in the following way:

- close both shut-off valves of the dirt separator
- unscrew the black magnet/filter cap and remove the stainless-steel filter
- clean the filter with clean water
- unscrew the allen key on the black magnet/filter cap and remove the magnetic bar
- then clean the magnets and the black cap with clean water
- then put the magnetic bar back into the black cap and tighten the allen key
- place the stainless-steel filter back in the dirt separator
- refit the black cap (hand-tight) on the brass body
- open the bottom valve and check for any leakage
- open the air vent, let the air escape and then close the air vent again
- open the top valve

Plus points dirt separator DDS

- the installation does not have to be depressurised
- the installation does not need to be 'flushed'
- no topping up with oxygenated water required

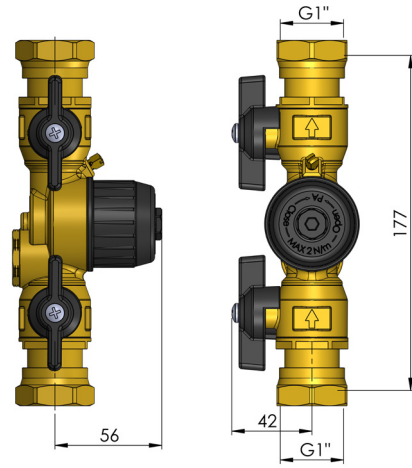

Technical Specifications

| | |
|-------------------------|---|
| Max. operating pressure | 3 bar |
| Max. pressure | 6 bar |
| Min./max. temperature | -10 to + 100 °C |
| Flow capacity | 3,250 l/h at 1 bar (KV 3.25) |
| Magnets | 10 pieces NEODYMIUM magnets Ø 10x2.6mm hole diameter 3.2mm |
| Stainless steel Filter | mesh size 0.35 mm (350 microns) |

Capacity Dirt Separator 22C

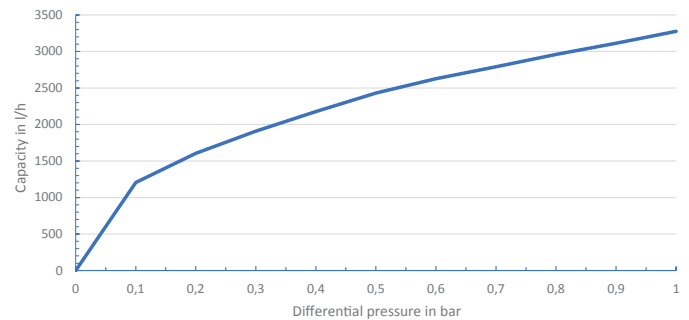

- 1" connection
- plug valve
- removable magnetic/filter cap
- magnetic bar
- fine-mesh stainless steel dirt filter
- air bleed valve
- allen key with magnetic bar

This illustration is slightly different and is only for explanation of parts.

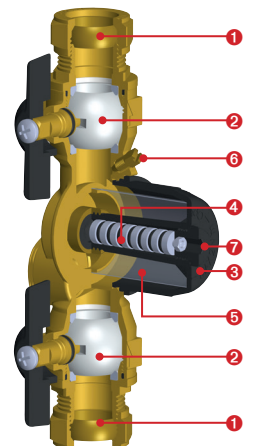

Dirt Separator DDS

Article number

1320-0-20-1