

Boiler Safety Unit DN20



DUCO

Boiler Safety Unit DN20 VR EN1717 - 3/4" x 3/4"

The Boiler Safety Unit is installed in connection with domestic water heaters (fired by electric, gas or oil) and must be fitted to the cold water inlet. The Boiler Safety Unit can be mounted vertically or at a right angle (by swapping the 4 safety valve and 5 boiler adapter).

The Boiler Safety Unit consists of a:

- 1 shut-off valve (for closing the cold water inlet)
- 2 built-in check valve (prevents recirculation of warm water into the cold water inlet)
- 3 drain+O-ring for emptying the tank/boiler (remove cap 8 and place adapter 3)
- 4 safety valve 3/4" (valve outlet must always point downward)
- 5 boiler adapter 3/4"
- 6 arrow flow indication
- 7 test plug
- 8 adapter

Continuous operating temperature max. 65°C/peak load max. 90°C (1 hour). Max. cap. 2.460 l/h at 1 bar (100kPa) differential pressure.
Before installing the Boiler Safety Unit please check our installation instructions.

Safety

Check whether the max. capacity and the opening pressure that are indicated on the valve match the values of the system.

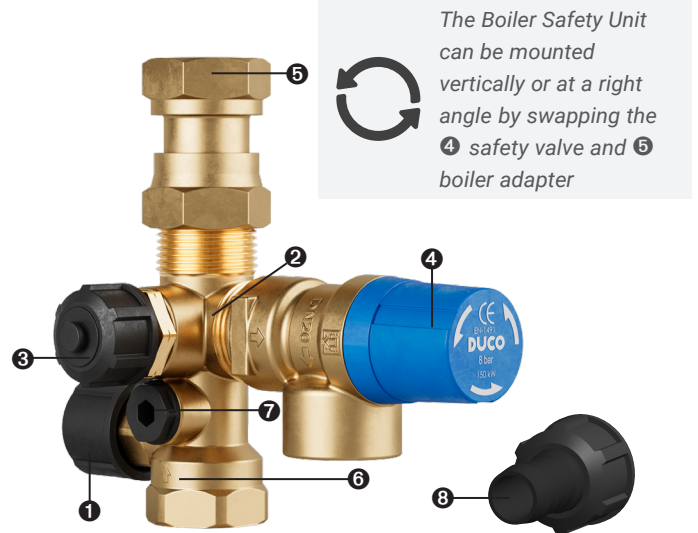
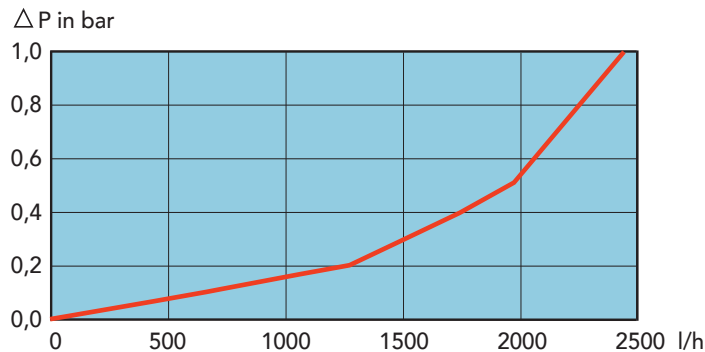

Brass CW625N

Norm:

- NEN-EN 1491 (safety valve)
- NEN-EN 1717 (test plug)
- NEN-EN 13959 (check valve)

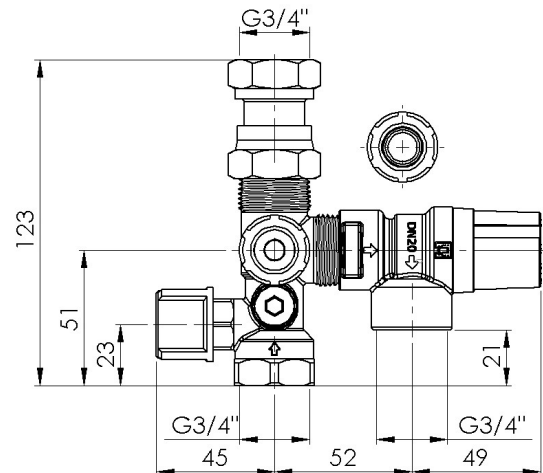

Boiler Safety Unit D20 VR EN1717

Article number	Set pressure bar	Max. capacity water heater kW
1210-0-66-01	6	150
1210-0-67-01	7	150
1210-0-68-01	8	150
1210-0-69-01	9	150
1210-0-70-01	10	150

PUCO

PenTec bv
Edisonweg 7
3442 AC Woerden
The Netherlands

Tel. +31 (0)182 503 100
E-mail info@pentecbv.nl
Internet www.duco.nl
www.pentecbv.nl