

# Boiler Safety Unit DN20



**DUCO**

# Boiler Safety Unit DN20 22 mm compression

The Boiler Safety Unit is installed in connection with domestic water heaters (fired by electric, gas or oil) and must be fitted to the cold water inlet.

The purpose of the use of this safety unit is

- 1) supply of water
- 2) being able to shut off the supply line
- 3) protecting against overpressure of the water heater
- 4) preventing warm water from flowing back into the cold water supply line.

The Boiler Safety Unit can be mounted vertically or horizontally.

Before installing the Boiler Safety Unit please check our installation instructions.

Continuous operating temperature max. 65°C/peak load max. 90°C (1 hour).

Max. cap. 6.975 L/h. at 1 bar (100kPa) differential pressure.

In accordance with the EN 1488 the Boiler Safety Unit is available in 6, 7, 8, 9 and 10 bar.

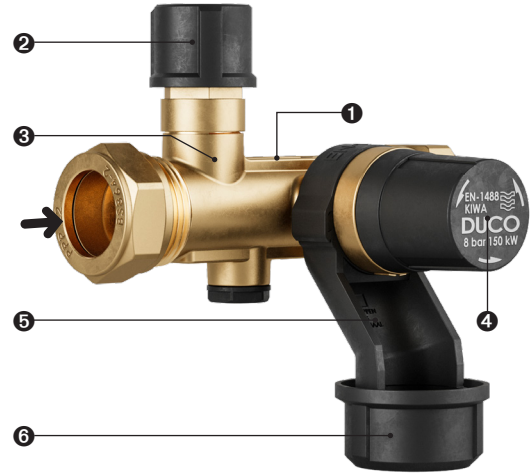

- 1 Arrow flow direction
- 2 Shut-off valve
- 3 Check Valve test plug
- 4 Relief valve
- 5 360° Rotatable funnel
- 6 Adapter flexible hose

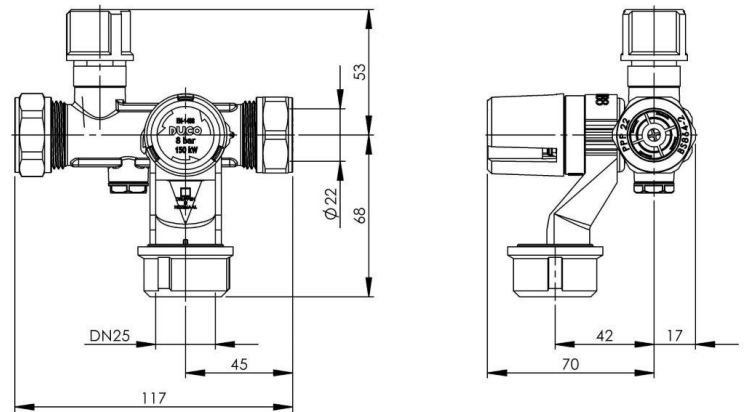
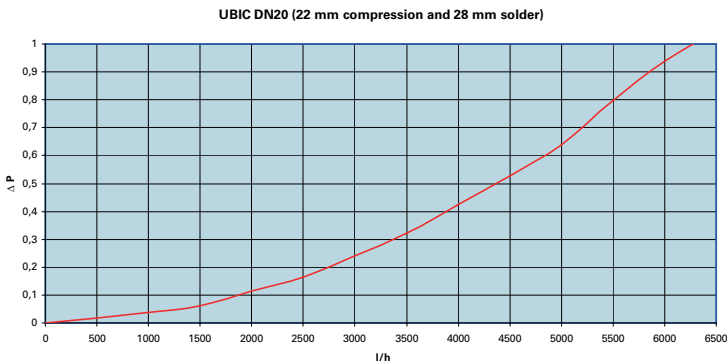

DVGW / UBA Konformität Hygiene für Bauteile aus Elastomeren

Produktgruppe P2  
 Werkstoff: E70  
 Prüfgrundlagen: UBA KTW-BWGL  
 Ablauf/expiry: 2028

## Safety Valves Unit DN20 22mm

Article number	Set pressure bar	Heating capacity kW
1203-0-06-01	6	150*
1203-0-07-01	7	150
1203-0-08-01	8	150*
1203-0-09-01	9	150
1203-0-10-01	10	150*

\* certified

# PUCO

PenTec bv  
 Edisonweg 7  
 3442 AC Woerden  
 The Netherlands

Tel. +31 (0)182 503 100  
 E-mail info@pentecbv.nl  
 Internet www.duco.nl  
 www.pentecbv.nl