

Safety Valves DN15



PUCO

Safety Valves DN15 1/2 x 1/2" KE

DUCO boiler valves to protect closed potable heated water systems against excessive pressure.

Application

The boiler valve has to be used in a closed drinking water system. Only use the valve in a dry and frostfree location. Min/Max. system temp. -10°C / +120°C

Safety

Check whether the max. capacity and the opening pressure that are indicated on the valve match the values of the system.

All Duco safety valves meet the requirements of the Pressure Equipment Directive (PED) "Directive 2014/68/EU Module B/Module D". The quality system also complies with the NEN-EN-ISO 9001.

Norm EN-ISO 4126-1.

Control knob	- ABS (black)
Adjustment screw	- PA 6 - 15% GF
Spring seat	- PBT 420 1001
Spring cover	- PA 6,6 - 30%GF
Valve disk	- PA 6 - 30%GF
Preset spring	- Spring steel (galvanised)
Membrane	- EPDM Shore Peroxide cured
Valve body	- Brass (CW617N) Pb<2,2%

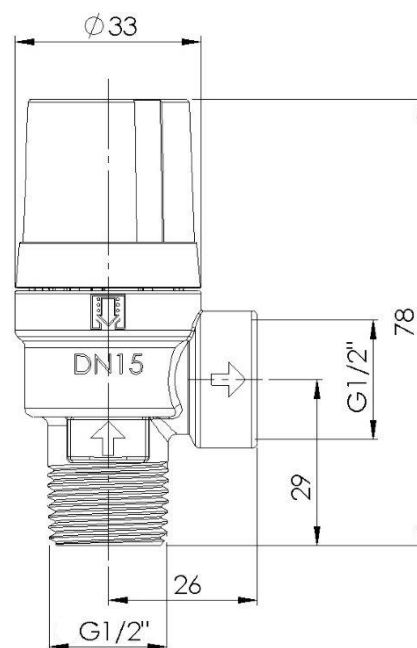
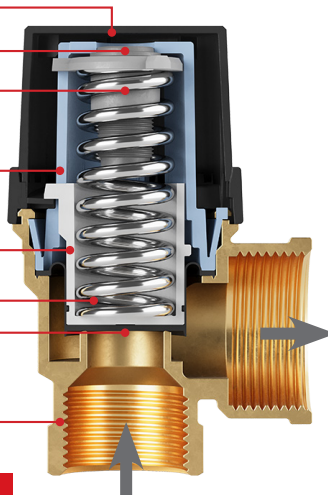

 This illustration is different and is only intended to explain the valve parts.



Safety Valves DN15

Article number	Set pressure bar	Heating capacity kW
1015-0-05-11	0,5	48
1015-0-05-11	1	64
1015-0-05-11	2	93
1015-0-05-11	2,5	107
1015-0-05-11	3	120
1015-0-05-11	4	148
1015-0-05-11	5	175
1015-0-05-11	6	200
1015-0-05-11	7	226
1015-0-05-11	8	252
1015-0-05-11	9	278
1015-0-05-11	10	302